

SOLAR WATER HEATING
CERTIFICATION AND RATING



SRCC OG-300

CERTIFIED SOLAR WATER HEATING SYSTEM

SUPPLIER: **Alternate Energy Technologies**
 1057 N. Ellis Road
 Jacksonville, FL 32254 USA
 (904) 781-8305
 (904) 781-1911 Fax
 (800) 874-2190

SYSTEM NAME: EagleSun
 SYSTEM TYPE: Indirect Forced Circulation
 LOCATION:

Description: Glazed Flat-Plate, Differential Controller, Immersed Coil Heat Exchanger with a Single Wall, No Load Side Heat Exchanger, Freeze Tolerance: F, Fluid Class I, Gas Auxiliary Tank

System Model_name	Cert 300#	Cert Date	Collector Panel Manufacturer	Collector Panel Name	Total Panel area(Sq-m)	Total Panel area(Sq-ft)	Solar Tank Vol(l)	Solar Tank Vol(g)	Aux Tank Vol(l)	Aux Tank Vol(g)	SEF
DX-G2-80-40	2010016A	10-FEB-10	Alternate Energy Technologies	AE-40	3.7	39.8	303	80	189	50	1
DX-G2-80-40	2010016A	10-FEB-10	Alternate Energy Technologies	MSC-40	3.9	42.1	303	80	189	50	1

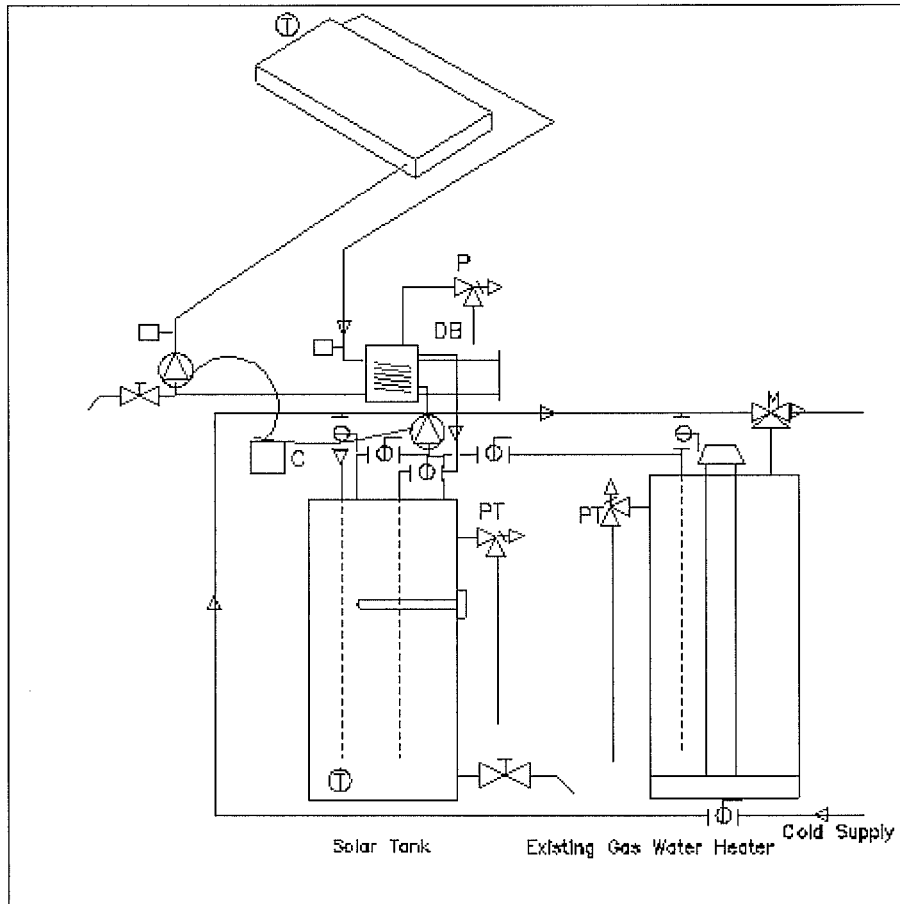

OG-300 System Reference:2010016A SVG Diagram Display

February, 2010
 Certification must be renewed annually, For current status contact:
 SOLAR RATING & CERTIFICATION CORPORATION
 c/o FSEC ♦ 1679 Clearlake Road ♦ Cocoa, FL 32922 ♦ (321) 638-1537 ♦ Fax (321) 638-1010

Return to Search