



IMPORTANT: Please take the time to read through the ENTIRE instructions prior to starting any work. Light Pipe material is very sharp when cut. Please use extreme caution when handling the light pipe. **AVOID LEAVING THE PIPE EXPOSED TO THE SUN WITHOUT THE PROTECTIVE COATING OR DIFFUSERS IN PLACE PRIOR TO INSTALLATION.**

PARTS LIST

- A. Clear UV Protected, High Impact Acrylic Dome
- B. (4) Phillips Head Stainless Steel ¼" Self-Tapping Screws
- C. Black Nylon Horse Hair Gasket (self-adhesive)
- D. Commercial Pure Grade, 1100 Series Aluminum Flashing
- E. (4) 1 ½" Phillips Head Stainless Steel Screws
- F. (8) 1 ½" Phillips Head Stainless Steel Screws
- G. (2) Screw Eye Bolts
- H. Support Cable Wire
- I. Heavy Duty Foil Tape
- J. Light Pipe, (2) 24" sections
- K. (4) Phillips Head Stainless Steel ½" Self-Tapping Screws
- L. White Nylon Horse Hair Gasket (self-adhesive)
- M. (2) Eye Bolt, Washer and Nut
- N. White Powder Coated Transition Box

TOOLS NEEDED

- Reciprocating Saw
- Measuring Tape
- Driver & Bits
- Phillips Screwdriver
- Clamp
- Stud Finder
- Marking Pencil
- Tin Snips
- Hammer

MATERIALS/TOOLS TO BUILD CURB

- 2" x 10" Pressure Treated Lumber
- Hand or Circular Saw
- Wood Screws
- Galvanized Nails
- Roofing Material (to match existing roofing)

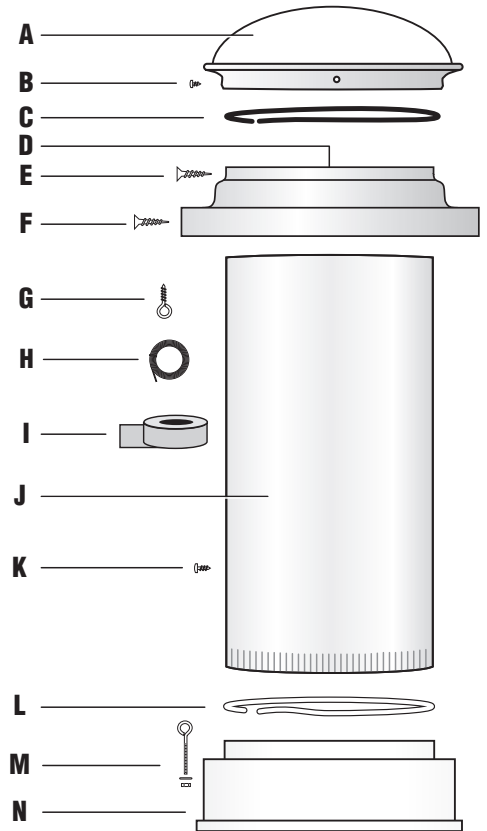

IMPORTANT: Prior to beginning installation, it is critical to plan the placement of the tubular skylight so that curb flashing and transition box are aligned. Install the ceiling grid system accordingly.

Step 1

Assemble a curb with the **outside** dimensions slightly smaller than the width of flashing (approximately 27.5" x 27.5"). **The size of curb will vary depending on roofing material.** Use pressure-treated lumber secured at all four corners with wood screws or galvanized nails (use 2" x 10" lumber - adhere to local building codes). **NOTE:** Do not build curb prior to being on job site.

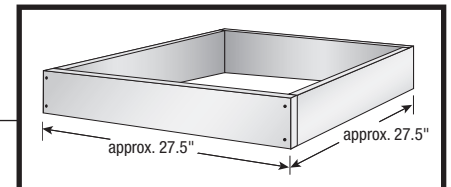

Step 2

From the roof, find the desired location to install the 21" unit. Ensure that there are no obstructions (wiring, framing, etc.) to hinder the installation. Mount the curb to the deck centering the curb over the space between the trusses. Using a reciprocating saw, cut out opening. **DO NOT CUT STRUCTURAL FRAMING.**

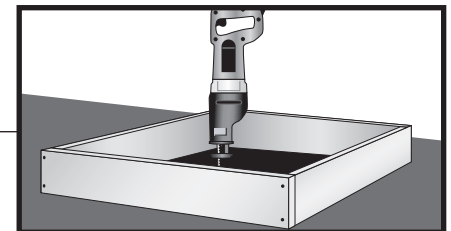

Step 3

Place curb over opening and toe-nail into existing roofing using galvanized nails. If necessary, build blocking to ensure the curb is secure. Wrap curb with roofing material to prevent leaking.

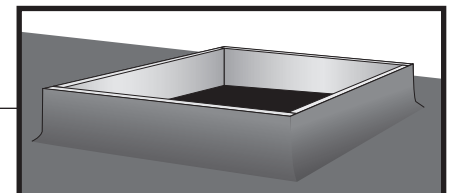

Step 4

Attach the skylight flashing (D) to the curb using the (8) 1 1/2" Phillips head stainless steel screws (F) provided through the pre-drilled holes on the skylight flashing lip. Peel the protective backing off the black nylon horse hair gasket (C) and apply gasket to the **INNER** lip the flashing collar.

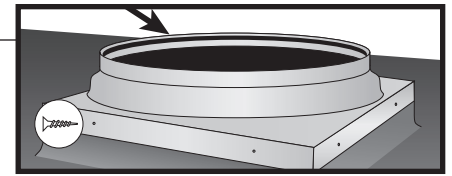

Step 5

To assemble light pipe (J), peel back the protective coating that covers the mirror coating about 1" from the opposite edge of the double sided tape. Remove paper backing from the double-sided tape and overlap tube ends and seal edges. Put pressure on both sides of seal to ensure a good bond. Secure tube using the (2) 1/2" self-tapping screws (K) provided. Then place foil tape (I) over the entire seam to strengthen seal. When joining two pipe sections together, place crimped end into the next section of pipe. Secure with (2) 1/2" self-tapping screws (K) provided and seal joints with foil tape (I).

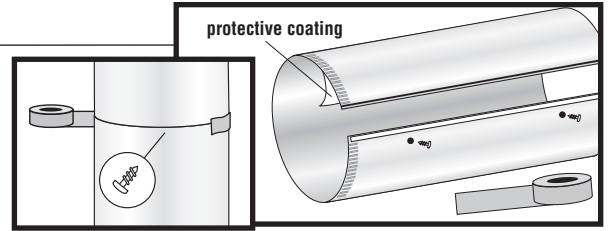

Step 6

Peel the protective backing off the white nylon horse hair gasket (L) and apply gasket on the **INSIDE COLLAR OF THE TRANSITION BOX (N)** 1/2" down from top of the collar.

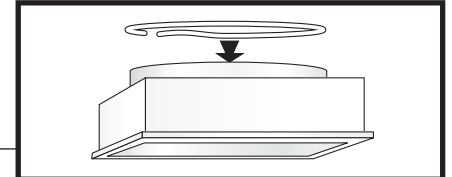

Step 7

Install the transition box (N) into the ceiling grid system. From the roof, slide the light pipe assembly with the crimped edge down into the transition box collar. Secure the light pipe to the flashing with the (4) Phillips head 1 1/2" screws (E) provided through the (4) pre-drilled holes on the flashing lip. (To prevent light pipe from slipping through the hole, clamp light pipe to flashing or have someone hold it in place until it is secured.) If there is excess pipe sticking out of the flashing, using tin snips, cut from the top down to the lip of the flashing and trim off the excess pipe. **(Use caution when handling the light pipe - edges of the light pipe are extremely sharp when cut).**

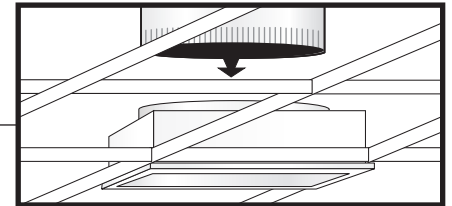

Step 8

For additional stability, screw the (2) screw eye bolts (G) into the two framing members on both sides of the unit. Attach the (2) eye bolts, washers and nuts (M) through the sides of the transition box (see figure). Attach the cable wire (H) from the screw eye bolt in the framing to the eye bolt on transition box.

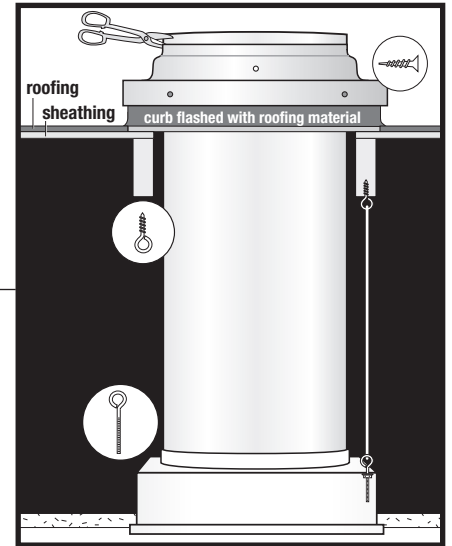

Step 9

Place the dome (A) on top of the flashing unit. Secure the dome to flashing by screwing in the (4) self-tapping Phillips head 1/4" screws (B) provided into the pre-drilled holes in the dome collar.

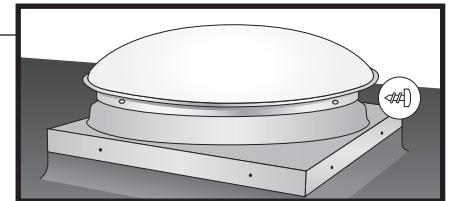

REGISTRATION CARD

Please fill out the registration card and mail to:

Tubular Skylight Registration
P.O. Box 71043
Phoenix, AZ 85050

Customer name: _____
Where unit was purchased: _____ Date purchased: _____
Street address: _____
City: _____ State: _____ Zip: _____
Phone: _____ Email: _____
Comments: _____