

IMPORTANT: Please take the time to read through the ENTIRE instructions prior to starting any work. Light Pipe material is very sharp when cut. Please use extreme caution when handling the light pipe. AVOID LEAVING THE PIPE EXPOSED TO THE SUN WITHOUT THE PROTECTIVE COATING OR DIFFUSERS IN PLACE PRIOR TO INSTALLATION.

PARTS LIST

1. Clear UV Protected, High Impact Acrylic Dome
2. (4) Phillips Head Stainless Steel 1/4" Self-Tapping Screws
3. Black Nylon Horse Hair Gasket (self-adhesive)
4. 1100 Series Aluminum Flashing
5. (8) Phillips Head Stainless Steel 1 1/2" Screws
6. Heavy Duty Foil Tape
7. Light Pipe
8. (4) Phillips Head Stainless Steel 1/2" Sheet Metal Screws
9. White Nylon Horse Hair Gasket (self-adhesive)
10. (3) Black Speed Nuts
11. (4) 1 1/2" Flathead Phillips Screws
12. White Powder Coated Trim Ring
13. (3) 1 1/2" Flathead Phillips Screws
14. High Impact Acrylic Prismatic Diffuser

TOOLS NEEDED

- | | | |
|------------------------|------------------|--------------|
| • Reciprocating Saw | • Clamp | • Tin Snips |
| • Measuring Tape | • Caulking Gun | • Flashlight |
| • Driver & Bits | • Stud Finder | • Ladder |
| • Phillips Screwdriver | • Marking Pencil | • Wire |

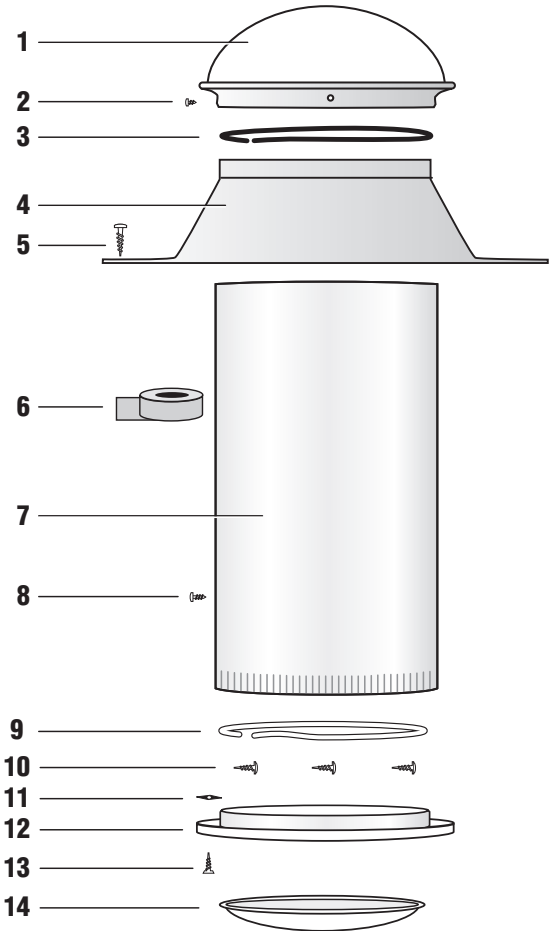

Step 1

Find the desired location for the ceiling trim ring and ensure that there are no obstructions in the attic space between the roof and ceiling. With a stud finder locate the ceiling joists and center the ceiling ring between joists as close to the desired installation area as possible. Mark the center of the ceiling ring, drill a hole and insert piece of wire bent at a 90 degree angle. Rotate the wire around 360 degrees. While rotating, feel for resistance that could indicate wire runs or other obstructions.

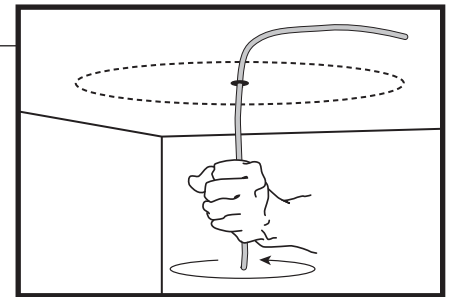

Step 2

If there are no obstructions, scribe a mark around the ceiling trim ring, see diagram. Using a drywall saw, cut out the scribed mark in the ceiling.

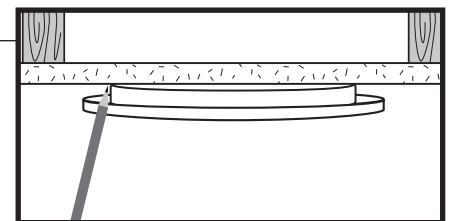

Step 3

Peel the protective covering off the white horse hair gasket and apply gasket to the **INNER** lip of the ceiling ring. This gasket ensures a dust free fit between the light pipe and the ceiling ring. Secure the ceiling ring to the ceiling by inserting a 1 ½" flathead Phillips screw into one of the three pre-drilled holes and screwing it up through the drywall into the speed nut provided. Repeat this process for all three screws.

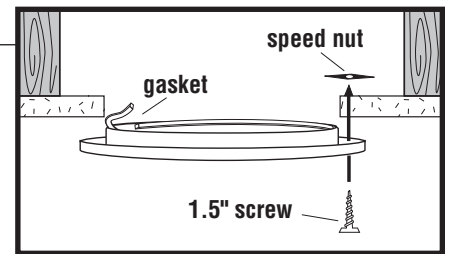

Step 4

For the roof cutout, place a step ladder under the ceiling ring hole and place a flashlight on top of the ladder, the resulting flashlight beam will mark the location for the centering hole of the flashing unit on the roof. With a drill bit and appropriate extension rods, drill a pilot hole in the marked location on the bottom side of the roof. If there is access to the attic space, a plumb bob may also be used.

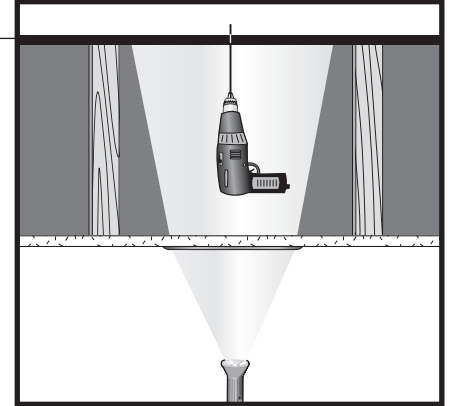

Step 5

On the roof, locate the centering hole and outline the diameter of the hole that the pipe will pass through by turning the flashing upside down and marking the inside lip of the flashing unit (see diagram).

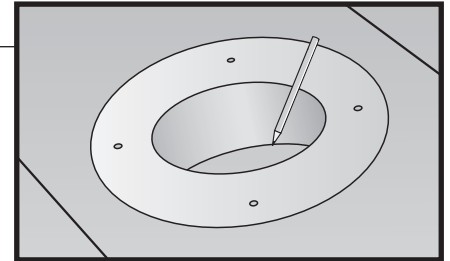

Step 6

With a reciprocating saw, cut the diameter of the hole 1" larger than the area marked in Step 1. **IMPORTANT:** The light pipe must pass between the roof rafters. **DO NOT CUT THROUGH ANY FRAMING MEMBER.**

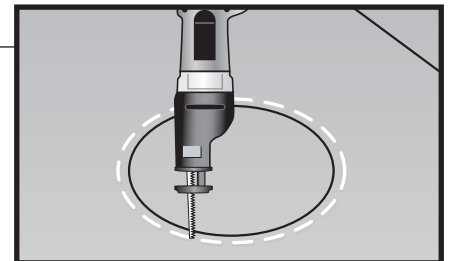

Step 7

Caulk **underside** of flashing with the provided caulking material. Two concentric rings of caulking material is sufficient. Turn flashing right-side-up and center over hole cut in Step 6. Press firmly down on flashing until caulk slightly squeezes out at the lip of the flashing.

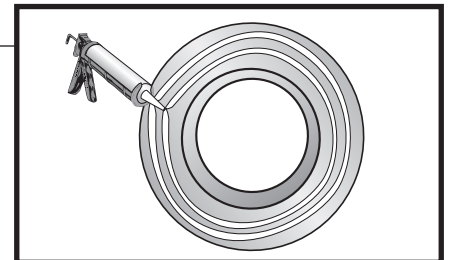

Step 8

Peel the protective backing off the black horse hair gasket and apply gasket on the inner lip of the flashing collar.

Secure flashing with (8) Phillips head 1 ½" screws provided. Evenly space the screws around the lip of the flashing. Place first screw at the 12:00 o'clock position, then next diagonally over from it at 6:00. The third screw should go at 9:00 and the next screw diagonally across at 3:00, etc. Caulk over the screw heads, since it will be exposed to the weather.

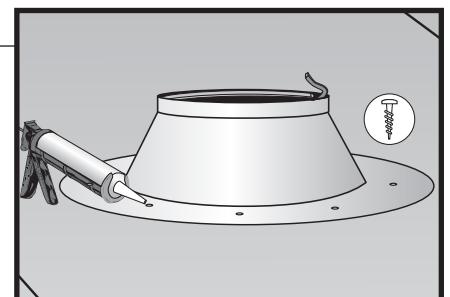

Step 9

To assemble light pipe, peel back the protective coating that covers the mirror coating about 1" from the opposite edge of the double sided tape, remove paper cover over double sided tape and overlap and seal edges. Put pressure on both sides of seal to ensure a good bond. Secure tube using the (2) 1/2" sheet metal screws provided. Then place foil tape over the entire seam to strengthen seal. When joining two pipe sections together, place crimped end into the next section of pipe. Secure with a 1/2" sheet metal screws provided and seal joints with foil tape.

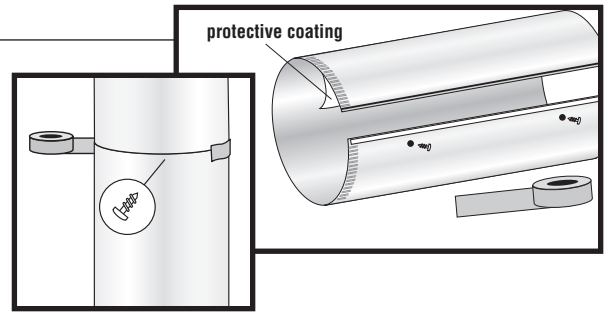

Step 11

Insert the pipe, crimped end down, through the flashing unit and gently rock pipe back and forth with slight downward pressure until pipe terminates evenly with the inner collar of the ceiling ring. Secure bottom of light pipe to ceiling ring with the tek screws.

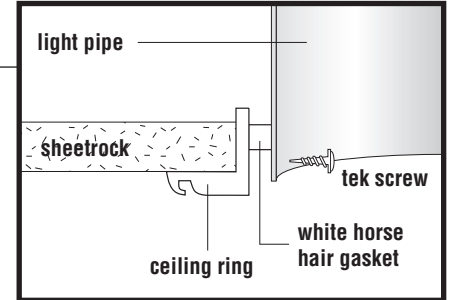

Step 12

If there is excess pipe sticking out of the flashing, using tin snips, cut from the top down to the lip of the flashing and trim off the excess pipe.

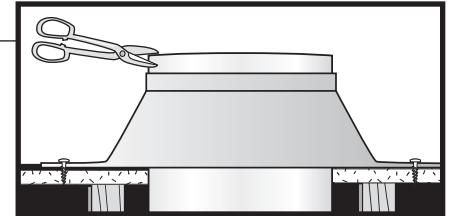

Step 13

Place dome on top of the flashing unit. Secure dome to flashing by screwing in the (4) self-tapping Phillips head 1/4" screws provided into the pre-drilled holes in the dome collar.

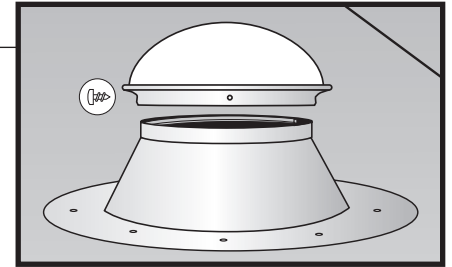

Step 14

Place the diffuser into the trim ring. Start with inserting one end of the diffuser lip into the channel on the inside of the trim ring. Slightly bend the diffuser and work the rest of the diffuser lip into the trim ring channel until the diffuser sits completely inside the trim ring.

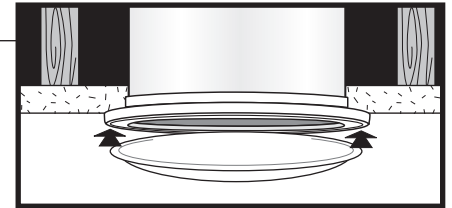

REGISTRATION CARD

Customer name: _____

Where unit was purchased: _____ Date purchased: _____

Street address: _____

City: _____ State: _____ Zip: _____

Phone: _____ Email: _____

Are you satisfied with the performance of the Greenergy Tubular Skylight? Yes No

Are you interested in other eco-friendly home products? Yes No

To help us improve our products, please include any comments: _____

*Please fill out the
registration card
and mail to:*

Tubular Skylight Registration
P.O. Box 71043
Phoenix, AZ 85050